



CENTRALISED HEAT RECOVERY UNIT

APPLICATION

Whole-house heat recovery unit, suitable for vertical installation.

SPECIFICATION

Outer fan casing manufactured from powder coated galvanised sheet steel providing long lasting and robust construction. The unit is finished in white RAL 9010.

Internal structure manufactured from EPP (expanded polypropylene) providing reduced sound emissions and maximised air tightness and thermal insulation.

EC external rotor motors fitted as standard for energy saving. Provided with integral thermal protection, mounted on sealed for life ball bearings.

Backward curved centrifugal impeller dynamically balanced and directly driven by the motor to provide a smooth airflow through the unit.

Highly efficient **counterflow heat exchanger** to maximise thermal recovery.

FEATURES & BENEFITS

Ease of installation: fixing bracket supplied to hang the unit easily on the wall.

Simplified electric wiring: the unit is supplied pre-cabled.

ISO Coarse 60% (G4) filters easy removable for cleaning. The unit is also provided with the **ISO ePM1 60% (F7) filter** accessory at the intake side.

Integral automatic bypass for free cooling during the summer season.

Automatic anti-frost protection to prevent frost building up on the exhaust side of the heat exchanger.

Two drainage holes to meet climate requirement.

Left/right configuration of the unit for mounting flexibility.

Tested to the latest standards: units are tested in the TÜV Rheinland accredited internal laboratory according to the operating document IEC OD 2048 (level CTF1) for the IEC 60335-1 and IEC 60335-2-80 Standards, meaning accurate, up to date information on electrical safety, performance and noise level that can be relied upon.

Unit thermal efficiency, air-leakage and energy efficiency measured at independent laboratory BRE (UK).

Designed and manufactured in accordance with EN60335-2-80 (Low Voltage Directive) and the EMC Directive (Electromagnetic Compatibility).

OPERATION

The unit is supplied with a multi-function LCD display (CTRL-DSP) for automatic control and convenience, providing:

- 3 speed settings (adjustable).
- Boost option.
- Holiday mode.
- Night mode.
- Weekly timer.
- Bypass setting.
- Airflow balancing.
- Filter replacement and fan failure indicator.
- Working hour counter.
- Setting saving and loading.
- Suitable for remote ambient sensors (SEN-HY, SEN-PIR).
- ModBus interface.
- Connection to remote pre/post heating element.
- Connection to remote water coil for heating.
- Left or Right hand configuration (air connection).



CTRL-DSP

(supplied as standard)

Example of a complete ventilation system

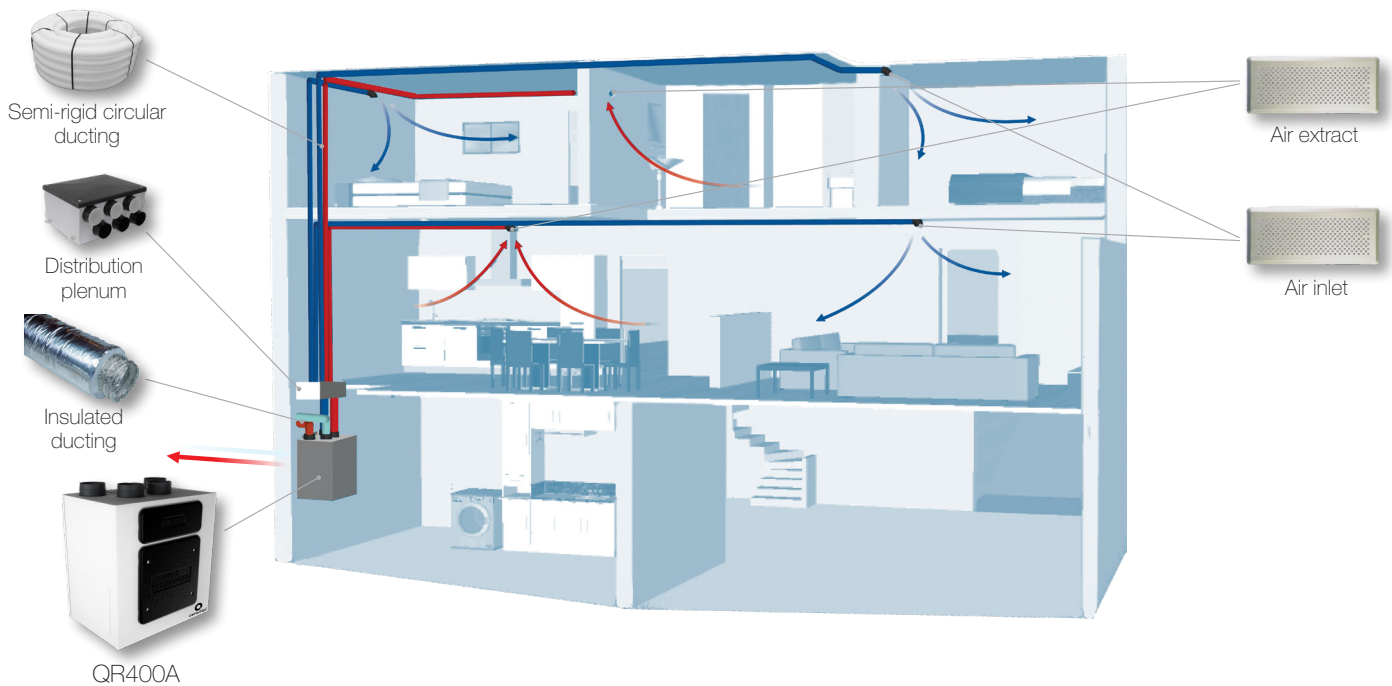

How it works: a continuous running heat recovery unit (QR400A) transfers heat from humid air extracted from wet rooms to warm incoming fresh air which is ducted to habitable rooms. Thanks to the easy-to-fit air distribution system each single ambient can be properly ventilate: the boost function enables rapid extract of increased moisture or pollutant levels. It also provides discrete installation and very quite operation.

Energy saving: the preheated/precooled fresh air and continuous air changes reduce the demand for additional heating/air-conditioning. The EC brushless motors significantly reduce the electricity consumption.

Indoor Air Quality: a correctly specified mechanical ventilation system can ensure the quality of the indoor air is constantly maintained for the health and well-being of the occupants as well as of the building. Duly maintained filters ensure that incoming air is suitably filtered of dust and pollen before it enters the home.

Dimensions (mm) and Weight (kg)

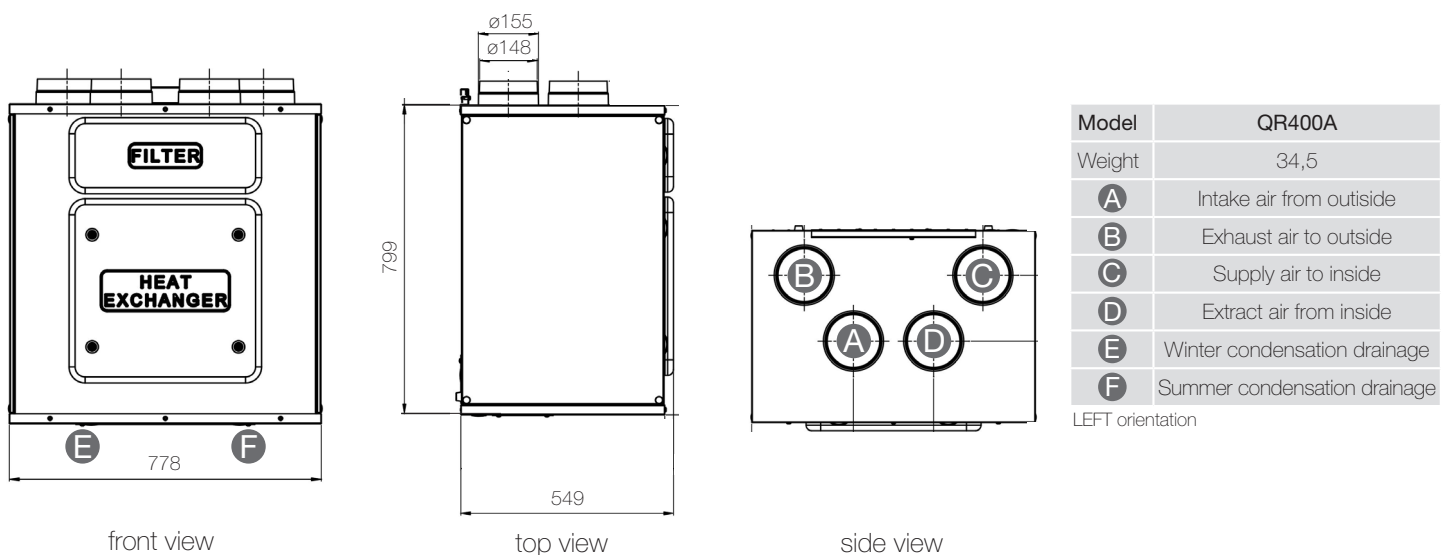

QR400A

Product fiche - ErP Directive, Regulations 1253/2014 - 1254/2014

a)	Mark	-	AERAULIQA		
b)	Model	-	QR400A		
c)	SEC class	-	A+	A	A
c1)	SEC warm climates	kWh/m ² .a	-17,3	-14,4	-11,8
c2)	SEC average climates	kWh/m ² .a	-42,1	-38,7	-35,7
c3)	SEC cold climates	kWh/m ² .a	-80,8	-76,6	-72,9
	Energy label	-	Yes		
d)	Unit typology	-	Residential - bidirectional		
e)	Type of drive	-	Variable speed drive		
f)	Type of Heat Recovery System	-	Heat recovery		
g)	Thermal efficiency of heat recovery	%	86		
h)	Maximum flow rate @ 100 Pa	m ³ /h	363		
i)	Electric power input (maximum flow rate)	W	160		
j)	Sound power level (L _{WA})	dBA	52		
k)	Reference flow rate	m ³ /h	254		
l)	Reference pressure difference	Pa	50		
m)	Specific power input (SPI)	W/m ³ /h	0,268		
n1)	Control factor	-	0,65	0,85	1
n2)	Control typology	-	Local demand control	Central demand control	Manual control (no DCV)
o1)	Maximum internal leakage rate	%	0,6		
o2)	Maximum external leakage rate	%	0,4		
p1)	Internal mixing rate	%	N/A		
p2)	External mixing rate	%	N/A		
q)	Visual filter warning	-	Visual filter warning on display		
r)	Instructions to install regulated grilles	-	N/A		
s)	Internet address for pre/disassembly instructions	-	www.aerauliqa.com		
t)	Airflow sensitivity to pressure variations	%	N/A		
u)	Indoor/outdoor air tightness	m ³ /h	N/A		
v1)	AEC - Annual electricity consumption - warm climates	kWh	1,4	2,4	3,4
v2)	AEC - Annual electricity consumption - average climates	kWh	1,9	2,9	3,8
v3)	AEC - Annual electricity consumption - cold climates	kWh	7,2	8,3	9,2
w1)	AHS - Annual heating saved - warm climates	kWh	20,8	20,4	20,1
w2)	AHS - Annual heating saved - average climates	kWh	46,1	45,2	44,5
w3)	AHS - Annual heating saved - cold climates	kWh	90,2	88,5	87,1
	Sound pressure @ 3m ⁽¹⁾	dB(A)	26		
	Ambient temperature max	°C	+40		
	Degree of protection IP	-	X4		
	Marking	-	CE		

- 220-240V ~ 50/60Hz.

- air performance measured according to ISO 5801 a 230V 50Hz, air density 1,2 Kg/m³.

- data measured in the TÜV Rheinland accredited internal laboratory according to the operating document IEC OD 2048 (level CTF1) for the IEC 60335-1 and IEC 60335-2-80 Standards.

(1) sound pressure level @ 3m in free field, breakout, speed 40%, for comparative purposes only.

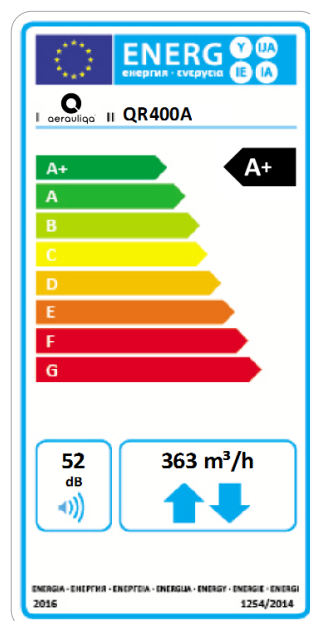

Performance curve

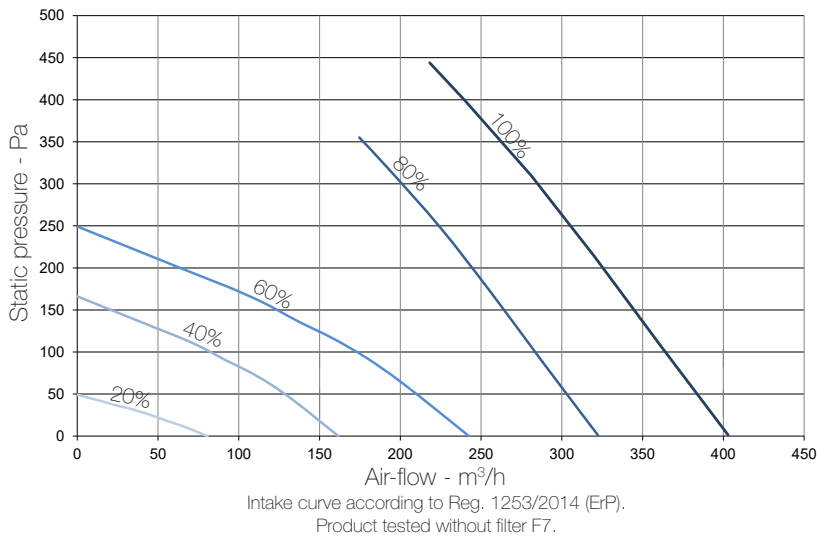

Speed %	W max	m³/h max
20	10	84
40	22	162
60	48	243
80	90	322
100	160	403

Sound level

	Lw dB - SOUND POWER OCTAVE BAND									Lp dB(A)
	63	125	250	500	1 K	2 K	4 K	8K	Tot	@3m
Speed 100%										
Intake	73	61	67	69	59	56	50	43	75	47
Supply	72	61	63	65	56	50	41	31	74	43
Extract	73	60	63	65	57	51	42	31	74	44
Exhaust	73	61	66	67	58	55	49	41	75	46
Breakout	71	64	62	67	59	53	45	33	74	45

	Lw dB - SOUND POWER OCTAVE BAND									Lp dB(A)
	63	125	250	500	1 K	2 K	4 K	8K	Tot	@3m
Speed 80%										
Intake	65	61	68	67	58	56	49	41	72	46
Supply	63	59	63	64	55	49	40	29	69	42
Extract	64	59	63	63	56	51	41	30	69	42
Exhaust	64	60	66	67	57	54	48	41	71	45
Breakout	59	64	63	65	57	51	43	31	70	44

	Lw dB - SOUND POWER OCTAVE BAND									Lp dB(A)
	63	125	250	500	1 K	2 K	4 K	8K	Tot	@3m
Speed 60%										
Intake	55	55	67	55	49	47	40	31	68	39
Supply	53	53	62	52	47	41	32	22	63	35
Extract	58	52	60	51	47	42	32	22	63	34
Exhaust	55	54	66	55	49	47	40	31	67	39
Breakout	54	53	59	52	48	43	33	23	62	34

	Lw dB - SOUND POWER OCTAVE BAND									Lp dB(A)
	63	125	250	500	1 K	2 K	4 K	8K	Tot	@3m
Speed 40%										
Intake	50	50	57	46	39	37	27	20	59	30
Supply	52	50	56	43	36	30	22	15	58	28
Extract	52	47	54	43	37	31	21	15	57	26
Exhaust	51	49	55	47	39	36	28	21	58	29
Breakout	52	47	52	44	38	31	21	15	56	26

Lp dB(A) @3m for comparative purposes only